

NEW



## LOADALL | 516-40

Gross power: 35kW/47hp | Lift capacity: 1,600kg | Lift height: 4,000mm



## DESIGNED FOR PRODUCTIVITY.

FIRST AND FOREMOST, WE DESIGN OUR LOADALL RANGE FOR ULTIMATE PRODUCTIVITY. THUS YOU'LL FIND THAT THE 516-40 IS ENGINEERED TO PROVIDE VERSATILE PERFORMANCE, POTENT POWER AND EXCELLENT MANOEUVRABILITY, WHILST MAKING THE MOST OF EVERY DROP OF FUEL.

### Maximum manoeuvrability.

- 1 The JCB 516-40's compact wheelbase and tight steering lock angles ensure a compact turning circle for excellent manoeuvrability.
- 2 This machine can gain access to even the smallest environments thanks to a low overall height of 1800mm and a narrow width of 1560mm.
- 3 When space is limited, you'll be glad of the excellent manoeuvrability afforded by our permanent 4-wheel steer system.

### Versatile hydraulics.

- 4 Choose from two quickhitch options: JCB Compact Toolcarrier or skid-steer. Available in either manual or hydraulic pin locking.

- 5 Lift capacity is impressive for such a small machine. You can raise 1600kg throughout the lift arc of the boom, right up to the full height of 4m. What's more, there's a 1000kg lift capacity at 2m forward reach, making it easy and safe to load or unload lorries full of brick packs.





**A fine driveline.**

**6** For ultimate traction and performance in soft muddy areas, we've equipped the 516-40 with four-wheel-drive as standard.

**7** The Tier 3-compliant JCB Diesel by Kohler engine in this compact telehandler produces 130Nm of torque at just 1600 rpm.

**8** We've fitted a versatile hydrostatic transmission that enables operators to make fine movements in tight spaces. There's also a transmission dump on the foot brake for superb multi-functioning and increased power when loading or rehandling.

**Adaptable performance.**

**9** JCB offers a wide range of tyres to suit many different working environments.

**10** With a single auxiliary service, you can operate attachments that require hydraulic power to function with your 516-40.



## STRENGTH AND DURABILITY.

THE NEW JCB 516-40 MAY BE A COMPACT TELEHANDLER, BUT IT CERTAINLY ISN'T A FRAGILE ONE. CHARACTERISTICALLY, WE'VE USED INNOVATIVE, EXHAUSTIVE DESIGN AND CONSTRUCTION PROCESSES TO ENSURE THAT STRENGTH, DURABILITY AND RELIABILITY ARE BUILT INTO EVERY AREA.

### Parts of the process.

**1** To achieve the very highest levels of quality, we use state-of-the-art manufacturing processes like robot machining and precision paint technology, as well as innovative assembly techniques.

**2** The new Loadall range's stringent testing programme has included prolonged high stress loading of the chassis, boom and other key components, as well as repeated transmission use over thousands of cycles.

**3** You can be assured of long-term corrosion protection because we dip all JCB cabs in electrophoretic alloy before the painting process begins.



## Tougher by design.

- 4** The 516-40's one-piece fully welded chassis maximises strength and minimises weight.
- 5** For ultimate strength and durability, we've built in large boom overlaps of 0.5m.
- 6** Our hydraulic cylinders have friction-welded eye-ends for extra strength, plus all pivots use hardened pins.
- 7** All of the hydraulic hoses on the JCB 516-40 are intelligently routed through the boom, affording them maximum protection against damage.



4



5



7



## COMFORT AND EASE OF USE.

AN ESSENTIAL ELEMENT OF MACHINE PRODUCTIVITY IS OPERATOR PRODUCTIVITY. FOR THIS REASON, THE JCB 516-40'S CAB IS A PLEASANT PLACE TO WORK, WITH HIGH LEVELS OF COMFORT, LOW-EFFORT CONTROLS AND GOOD VISIBILITY, KEEPING DRIVERS RELAXED, FRESH AND ALERT.



Standard-fit tinted cab glass reflects 30% of the sun's energy for increased operator comfort.

### Total control.

**1** The 516-40's single-lever joystick controls with proportional auxiliaries are quick and easy to use, offering precise control.

**2** Visibility is excellent for such a compact telehandler; there's a large roof screen and optional front and rear work lights. Control switches are ergonomically laid-out and backlit for easy recognition and good visibility at night.



Operators can work to their choice of soundtrack with our optional-fit radio speaker.



### Comfortably better.

**3** You have a choice of cab – with or without air conditioning – to equip the 516-40 for any climate. Whichever cab you choose, you'll find it's large and spacious, with a wide-opening door for easy access.

**4** The auxiliary service has an adjustable constant flow, allowing operators to programme their desired flow rate for operating attachments

**5** During operation, the upper portion of the stable-style door can be folded back to allow increased airflow into the cab.

**6** There's a choice of two seating options (cloth or vinyl) to tailor your 516-40 to operator requirements in different applications.



## EFFICIENT OPERATION.

AS AN OWNER, YOU'LL WANT YOUR LOADALL TO PROVIDE VALUE FOR MONEY IN BOTH THE SHORT AND LONG TERM. YOU'LL BE PLEASED TO KNOW, THEREFORE, THAT THE NEW 516-40 NOT ONLY OFFERS VERY LOW OPERATIONAL COSTS; IT ALSO HOLDS ITS VALUE, AND FOR GOOD REASON.

### Low running costs.

- 1 Fuel-efficient matching of the transmission and hydraulics is ensured because the 516-40's JCB Diesel by Kohler engine produces high levels of torque at engine speeds as low as 1600rpm.
- 2 JCB Loadalls have a well-earned reputation for delivering reliable performance with minimum downtime.
- 3 To get the most for your money, you need your machinery to keep working hard even in hazardous environments; for this reason, steering rams on the 516-40 are located high on the chassis out of harm's way. You can also choose optional front screen guard for added protection from falling debris.



### Most wanted.

4 A big part of keeping resale values healthy is our continued innovation in all areas of design and build. For example, the 516-40 has a patented offset single-spine chassis design, allowing the cab to sit low in the chassis, keeping machine height down without compromising on comfort.

If you ever want to sell your Loadall, you'll want it to look its best. That's why we use a durable powder coat paint that's resistant to stone chips.

When you buy a JCB Loadall, you buy a machine that's sought after around the world for its legendary productivity and build quality. This level of demand keeps residuals correspondingly high.



4



# SAFETY AND SECURITY.

SAFETY IS PARAMOUNT ON ANY SITE, SO WE'VE DESIGNED THE NEW JCB 516-40 TO TAKE GOOD CARE OF ITSELF, ITS OPERATORS AND ANY BYSTANDERS. WHAT'S MORE, WE'VE EQUIPPED IT WITH COMPREHENSIVE SECURITY FEATURES TO KEEP THIEVES AT BAY.

## Safe and secure.

- 1 JCB's Adaptive Load Control system automatically prevents the machine from over-turning forwards during heavy load handling.
- 2 Bystanders are safeguarded by our standard-fit reversing alarm.
- 3 The JCB 516-40 has hose burst check valves (HBCVs) to protect the rams from collapse in the event of a hose failure.
- 4 For added peace of mind, the 516-40's cab is ROPS (Rollover Protection System) and FOPS (Falling Objects Protection System) certified, keeping its operator protected at all times.

Cesar is a simple and effective method of machine identification and registration operated across the UK and Ireland by the Police. JCB fully supports the initiative and offers it as a factory fit across our full UK range of machines.



A seat safety switch disables forward/reverse if the operator isn't seated.

## AT YOUR SERVICE.

THE JCB 516-40 IS AN EXCEPTIONALLY EASY MACHINE TO SERVICE AND MAINTAIN. AFTER ALL, KEEPING DOWNTIME TO A MINIMUM IS CRUCIAL TO ACHIEVING ULTIMATE PRODUCTIVITY. IN SHORT, KEY COMPONENTS ARE HARD-WEARING AND STRAIGHTFORWARD TO ACCESS.



### Minimised downtime.

- 1 All daily checks and grease points are easily located at ground level on the JCB 516-40.
- 2 Every filter is simple to access for fast, easy servicing; the air filter features a double-element construction to aid cleaning.
- 3 The battery is located under the bonnet but it's also accessible using only the ignition key, with no special tools required.

4 Filling the diesel tank is straightforward and can be done from ground level.

5 JCB wear pads use a dry lubricant system which prolongs degradation and, therefore, service life. Accordingly, wear pad service intervals are 500 hours, compared with 250 hours on typical competitor machines.



# LIVELINK, WORK SMARTER.

**LIVELINK IS AN INNOVATIVE SOFTWARE SYSTEM THAT LETS YOU MANAGE JCB MACHINES REMOTELY – ONLINE, BY EMAIL OR BY MOBILE PHONE. ACCESS EVERYTHING FROM MACHINE ALERTS TO FUEL REPORTS AND HISTORY INFORMATION, WITH ALL DATA STORED AT A SECURE CENTRE.**

## Productivity and cost benefits

By providing information like idle time monitoring and machine fuel consumption, JCB Livelink helps reduce your fuel usage, saving money and improving productivity. Machine location information can help improve efficiency and perhaps even reduce insurance costs.

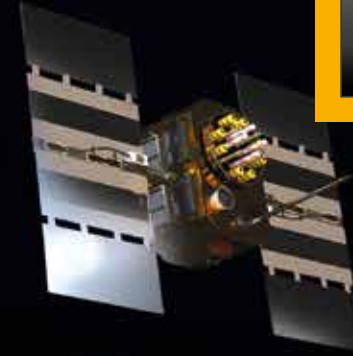

## Maintenance benefits

Manage machine maintenance easily – accurate hours monitoring and service alerts improve maintenance planning, while real-time location data helps you manage your fleet. Critical machine alerts and maintenance history records are also available.



## Security benefits

Livelink's real-time geofencing alerts tell you when machines move out of predetermined zones, and real-time curfew alerts inform you of unauthorised usage. Further benefits include real-time location information.



## VALUE ADDED.

JCB'S WORLDWIDE CUSTOMER SUPPORT IS FIRST CLASS. WHATEVER YOU NEED AND WHEREVER YOU ARE, WE'LL BE AVAILABLE QUICKLY AND EFFICIENTLY TO HELP MAKE SURE YOUR MACHINERY IS PERFORMING TO ITS FULL POTENTIAL.



1

1 Our Technical Support Service provides instant access to factory expertise, day or night, while our Finance and Insurance teams are always on hand to provide fast, flexible, competitive quotes.

2 The global network of JCB Parts Centres is another model of efficiency; with 16 regional bases, we can deliver around 95% of all parts anywhere in the world within 24 hours. Our genuine JCB parts are designed to work in perfect harmony with your machine for optimum performance and productivity.



2

3 JCB Assetcare offers comprehensive extended warranties and service agreements, as well as service-only or repair and maintenance contracts. Irrespective of what you opt for, our maintenance teams around the world charge competitive labour rates, and offer non-obligation quotations as well as fast, efficient insurance repair work.



3

Note: JCB LIVELINK and JCB ASSETCARE may not be available in your region, so please check with your local dealer.

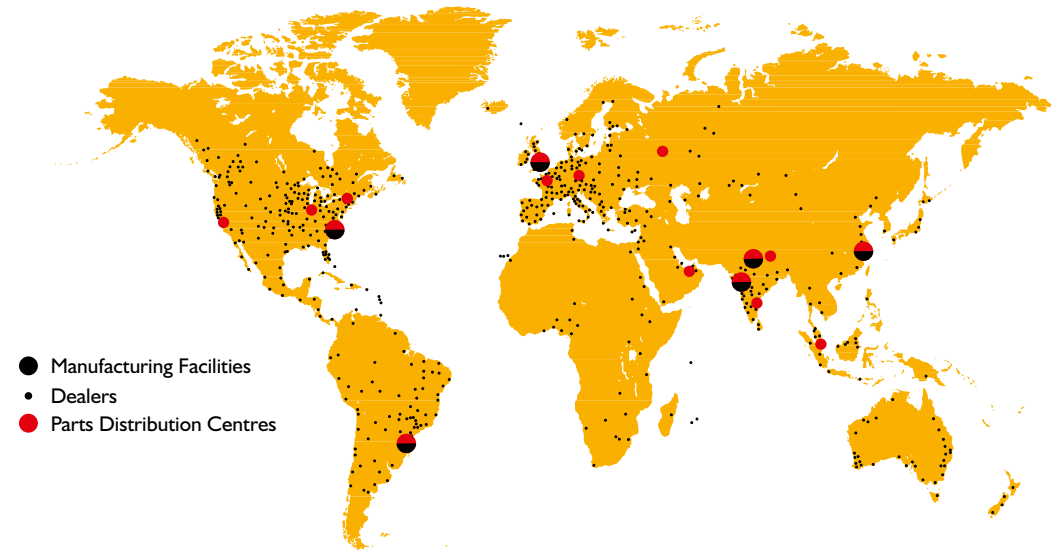

STATIC DIMENSIONS

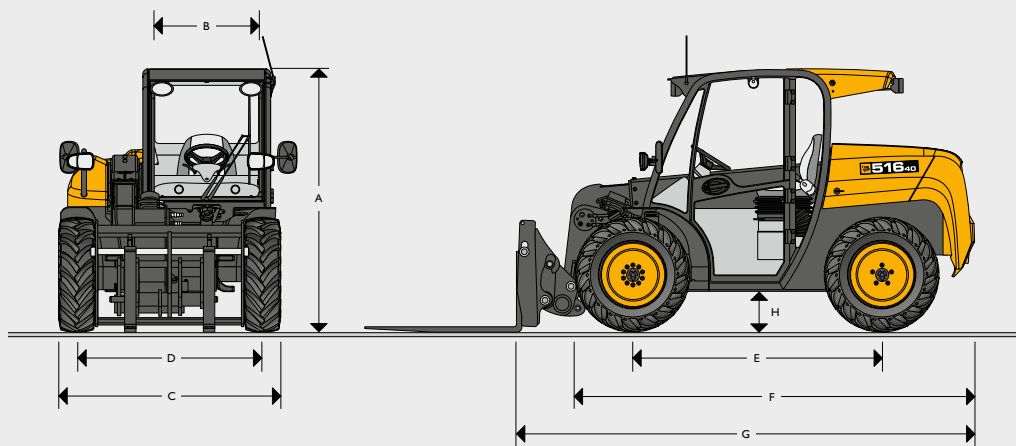

Machine model		516-40
A Overall height	m	1.8
	Overall height with wiper	m
B Inside width of cab	m	0.87
C Width over tyres	m	1.56
D Front track	m	1.3
E Wheelbase	m	1.75
F Overall Length to front tyres	m	2.8
G Overall length to front carriage	m	3.23
H Ground clearance	m	0.24
	Outer turn radius over tyres	m
Weight	kg	3421
Carriage roll back angle at ground	degrees	35/30*
Carriage dump angle at max height	degrees	30/35*
Tyres	traction	255/75-15.3
	industrial	10.0/75-15.3
	semi-turf	10.0/75-15.3

\* Compact Loadall Quickhitch/Skid Steer Quickhitch

LIFT PERFORMANCE

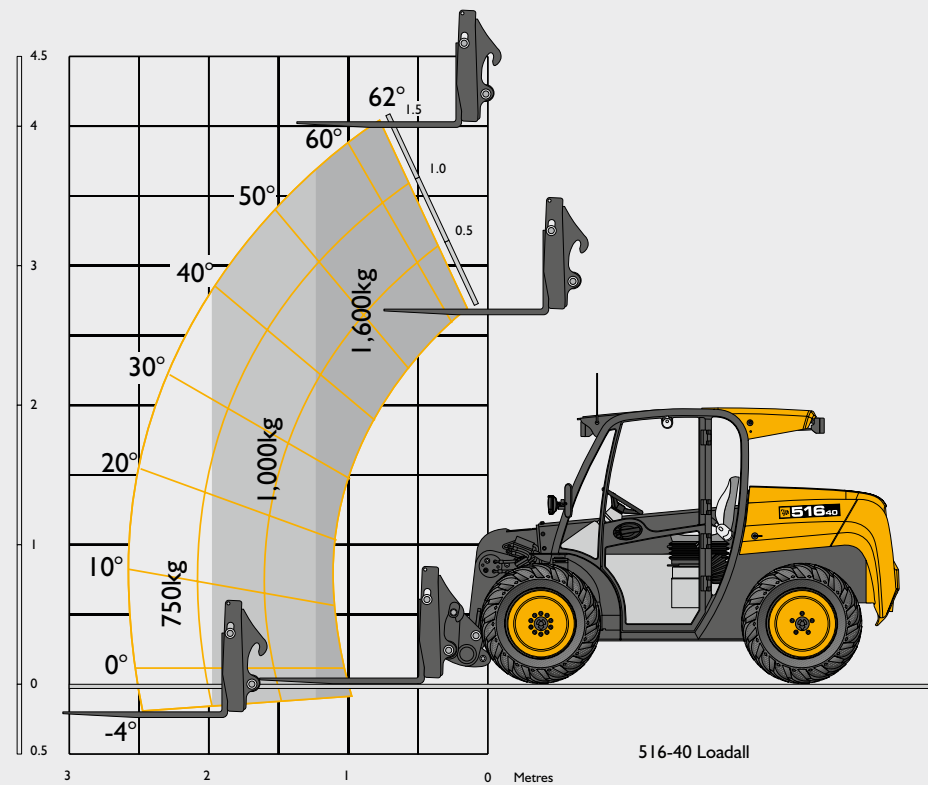

Machine model		Compact Tool Carrier Quickhitch	Skid Steer Quickhitch
Lift capacity to full height	kg	1600	1600
Lift capacity at full reach	kg	750	750
Payload at 2.0m boom extension	kg	1000	1000
Max. lift height	mm	4045	4060
Reach at max. lift height	mm	460	380
Maximum forward reach	mm	2535	2455

Complies with stability test EN 1459 Annex B.

ENGINE		
Machine model		516-40
Model		KOHLER KDW2204 CHD
Displacement	litres	2.2
Fuel		Diesel
Cooling		Liquid
Bore	mm	88
Stroke	mm	90.4
Gross power @2800 rpm		
ISO 14396	kW (hp)	35 (47)
Gross torque @ 1600rpm		
ISO 14396	Nm	130
Emission certification		EC Stage IIIA/USA EPA Tier 3
Engine oil service intervals		500 hours

TRANSMISSION			
Machine model		516-40	
Type		Hydrostatic	
Model		Rexroth AA4VG	
		Forward	Reverse
Low range	kph	13	13
High range	kph	26	26

ELECTRICAL SYSTEM		
System voltage	Volt	12
Alternator output	Amp hour	80
Battery capacity	Amp hour	62

HYDRAULICS		
Machine Model		516-40
Main service pump operating system pressure	bar	230
Flow at system pressure (@2800rpm)	ltr/min	56
Maximum auxiliary flow (@230bar)	ltr/min	56
Cycle times		seconds
Boom raise		6.6
Boom lower		3.9
Extend		5
Retract		3.7
Bucket dump		2.5
Bucket crowd		3.3

SERVICE CAPACITIES		
Fuel tank	litres	50
Hydraulic tank	litres	58
Engine oil sump	litres	8
Engine coolant system	litres	22

BRAKES
<b>Service brakes:</b> Hydraulically activated, drum brake on the front wheel motors.
<b>Parking brake:</b> Manually operated drum brake on the front wheel motors.

BOOM AND CARRIAGE
Boom is manufactured from high tensile steel. Low maintenance, hard wearing pads. JCB compact tool carrier parallel lift carriage with manual or hydraulic pin locking, accepts forkframe with integral pallet forks and a wide range of attachments. <b>Compact Tool Carrier:</b> Compact Loadall compatibility. <b>Skid Steer Tool Carrier:</b> Skid steer universal compatibility hitch.

ELECTRICS
12v negative earth. 62 AH heavy duty battery. 80 amp alternator. Full road lighting. Reversing light. Direction indicators. Hazard warning. Reverse alarm.

STEERING
Full hydrostatic power steering. Permanent 4WS with 32° lock front and rear axles provides exceptional manoeuvrability

CAB
Quiet, safe and comfortable cab conforms to ROPS ISO3471 and FOPS ISO 3449. Radio console. Arm rest. Tinted glass all round with laminated front and roof screen. Front, rear screen wash/wipe and heater/screen demister. Opening door window. Optional air conditioning or face-level fan. Visual warning system for coolant temperature, engine oil pressure, air cleaner, battery charge, transmission oil pressure, engine temperature, fuel gauge and hourmeter.
Boom control joystick incorporating forward/reverse switch. Throttle and brake pedals floor mounted. Optional fabric or vinyl adjustable, suspension seat with side mounted park brake lever. Automatic eye level audio-visual load moment indicator warning system receiving a signal from a load sensor on the rear axle. This system continuously monitors the machine's forward stability and leaves the operator in control at all times.

OPTIONS AND ACCESSORIES
<b>Options:</b> Road lights, work lights, rotating flashing beacon, fire extinguisher, front screen guard, sun blind, traction, industrial or semi-turf tyres, mechanical or hydraulic compact tool carrier quickhitch or Skid Steer quickhitch, battery isolator, air conditioning, face level fan, radio/speaker kit, reverse alarm, high-vis mirror, cesar data tag kit, wheel chock, grease gun, lifting points.

<b>Attachments:</b> GP shovel with toeplate, industrial or floating forks, power grab, sweeper/collector.
---



**ONE COMPANY, OVER 300 MACHINES.**

Your nearest JCB dealer

**LOADALL 516-40**

Gross power: 35kW/47hp    Lift capacity: 1,600kg    Lift height: 4,000mm

JCB Sales Limited, Rokeceter, Staffordshire, United Kingdom ST14 5JP.

Tel: +44 (0)1889 590312    Email: [salesinfo@jcb.com](mailto:salesinfo@jcb.com)

Download the very latest information on this product range at: [www.jcb.com](http://www.jcb.com)

©2009 JCB Sales. All rights reserved. No part of this publication may be reproduced, stored in a retrieval system, or transmitted in any form or by any other means, electronic, mechanical, photocopying or otherwise, without prior permission from JCB Sales. All references in this publication to operating weights, sizes, capacities and other performance measurements are provided for guidance only and may vary dependant upon the exact specification of machine. They should not therefore be relied upon in relation to suitability for a particular application. Guidance and advice should always be sought from your JCB Dealer. JCB reserves the right to change specifications without notice. Illustrations and specifications shown may include optional equipment and accessories. All images are correct at time of print. The JCB logo is a registered trademark of J C Bamford Excavators Ltd.

